

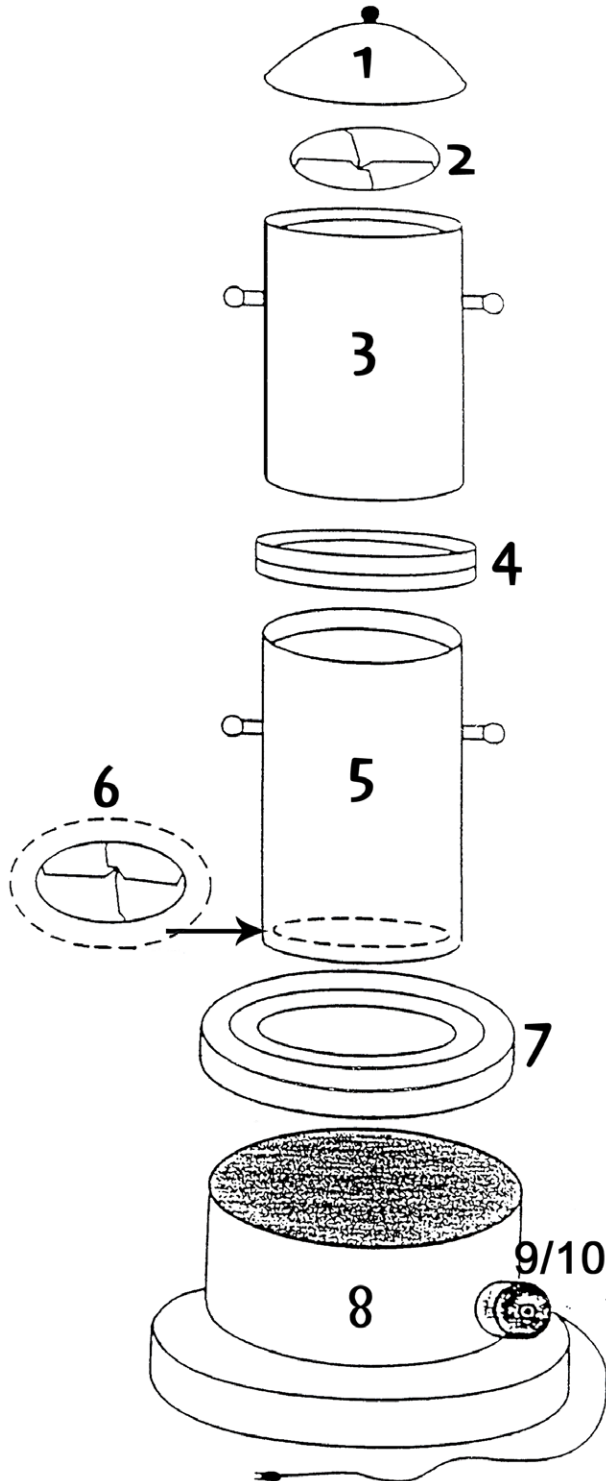

Vertical Steamer

Item # STEAM00 / STEAM01 / STEAM02

Vertical Steamer Components:



- 1 STEAM59: White Dome Lid
- 2 STEAM58: Quadrangle Ring
- 3 STEAM56: Short Cylinder (24"/0.3 m)
- 4 STEAM57: Separator
- 5 STEAM55: Long Cylinder (33"/0.84 m)
- 6 Quadrangle ring welded to bottom of STEAM55
- 7 STEAM 52: Pot Ring
- 8 STEAM51: Pot
- 9 STEAM53: Element 120 volt
- or
- 10 STEAM54: Element 240 volt

Not Shown

VERTICAL STEAMER CORES

- STEAM03: Vertical Steamer Core - Flexible
- STEAM06: Vertical Steamer Core - Rigid
- (NOTE: Cores sold separately from Vertical Steamer)

Steel Pin

08.06.21

Vertical-Steamer-Instructions

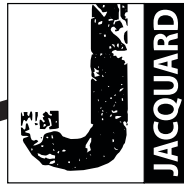

Vertical Steamer

Item # STEAM00 / STEAM01 / STEAM02

Core Assembly Components:



STEAM58 Quadrangle Ring



Steel Pin

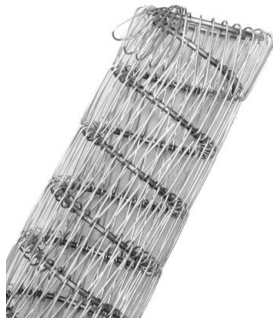

STEAM03 Flexible Steamer Core
(Not included with Vertical Steamer; please order separately)



STEAM06 Rigid Steamer Core
(Not included with Vertical Steamer; please order separately)

Core Assembly Instructions:

1. Place quadrangle ring on top of steamer core (flexible or rigid).
2. Push steel pin through the core, over the ring and through the other side.

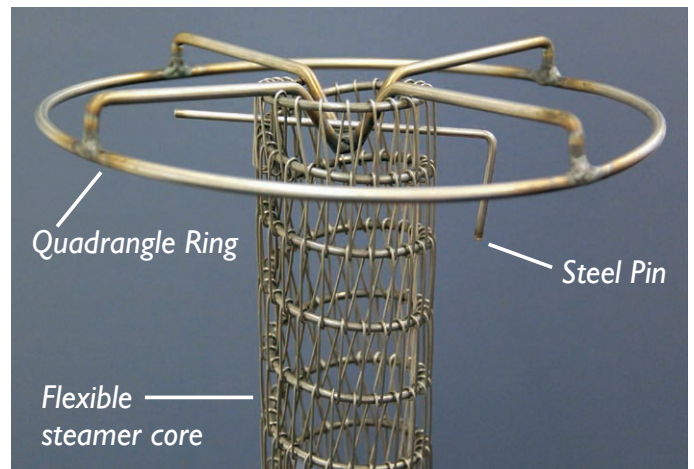

Quadrangle Ring

Steel Pin

Flexible steamer core

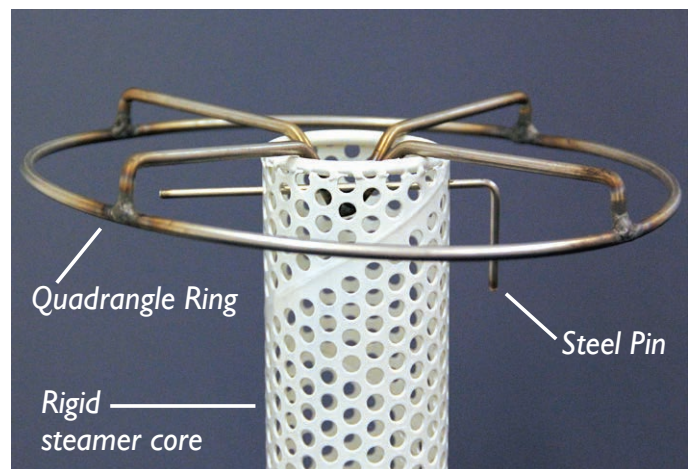

Quadrangle Ring

Steel Pin

Rigid steamer core

3. Place in steamer and settle on the base.



Vertical Steamer

Item # STEAM00 / STEAM01 / STEAM02

Vertical Steamer Instructions:

1. Painted fabric is rolled onto a 60"/152.40 cm long cardboard tube, flexible or rigid core (the full internal length of the Jacquard steamer) together with paper. Clean newsprint may be used for the rolling paper and should be the same width or a little wider than the fabric. For example, if the fabric is 48"/121.92 cm wide, then the paper should be about 50"/127 cm wide. It does not matter how long the paper is cut, because you can overlap it to become continuous.
2. To roll the fabric and paper on the tube:
 - (a) First lay the fabric flat on your work surface. Be sure to smooth out any wrinkles so that they do not become steam-set into the fabric.
 - (b) Place a sheet of paper on top of the fabric.
 - (c) Place the tube at the leading edge of the fabric and paper and begin to roll them onto the tube. When you reach the end of a sheet of paper, overlap another sheet of paper and continue to roll the fabric and paper together onto the tube. Each fabric layer **MUST** be separated by paper to prevent any water spotting. Batches of smaller items can be steamed at one time. Roll one piece after another of fabric together with the paper, onto the tube as directed above. Roll your second piece with paper leaving a space between the two items. Continue with this procedure until all the pieces have been rolled onto the tube.
3. When the fabric and paper have been rolled onto the tube, an additional three layers of paper should be wrapped around the outside of the roll. Then tape the paper securely to keep the bolt intact. The finished bolt can be up to 8"/20.32 cm inches in diameter or 20-30 yards/18.29-27.43 m of 54"/137.16 cm wide fabric.
4. Fill the base of the steamer with water, so that it completely covers the heating coil by 2"/5.08 cm. Regular tap water is fine. If your water is hard, mineral deposits will build up and the heating element will require cleaning with vinegar more often.

WARNING: If the heating element is not completely covered with water, it is possible for the element to burn out, even though the steamer has an automatic safety turn-off switch in case the water runs dry.



5. Core Assembly and Adding Fabric:

- (a) Remove the white lid (left) from the top cylinder. Place the bolt of silk into the cylinder. Fix the bottom end of the tube onto the pronged holder at the bottom.



Vertical Steamer

Item # STEAM00 / STEAM01 / STEAM02

Vertical Steamer Instructions (continued)



(b) Connect the quadrangle ring (shown left) to the top of the steamer core by threading the provided steel pin through the core and top holder. Place the steamer core into the top of the bolt and replace the lid. The bolt will now be centered. If you are steaming a 36"/91.44 cm wide material or less, you only need to use the first cylinder, or hang the short tube via a string from the top pronged holder. It will center itself.

6. Turn on the steamer. Turn the black dial clockwise as far as it will go and leave it on until you are through steaming. The cylinder will get hot while it is in use. Although the Jacquard Steamer only requires 110 volts, it draws 16 amps. Therefore, it is recommended that when the steamer is in use, its circuit only be used for the steamer. It is best to unplug the steamer when it is not in use. The 220 volt heating element only draws 8 amps.
7. When the water in the steamer begins to boil (about 20 minutes), you will see steam escaping from the hole in the top of the lid. Once the water is about 212°F/100°C, begin timing. The thicker the bolt of fabric and paper, the longer the entire bolt will take to reach the temperature. The minimum steaming time is 45 minutes and the maximum time is about 2 hours. You cannot over-steam. If steaming for an extended period of time, the water level in the base should be checked to make sure that the heating coil is covered with water. With some practice, you will be able to accurately gauge your steaming time, based upon the amount of the fabric.



8. When you have finished steam setting, turn off the steamer and unplug it. It will be hot! Remove the top lid and bolt holder and carefully pull the bolt out of the cylinder. Unroll the bolt. It is not absolutely necessary to rinse the fabric once it has been steam set, but it is advisable. Rinsing assures that any excess dye (especially dark red or black) is removed before laundering. First, rinse in cold water, then rinse in warm water, then rinse in hot water. Last, rinse in cold water. Use Synthrapol or SolarFast Wash in every rinse except the last.

NOTE: This steamer can lose heat from the large surface area of the stainless steel. Measure the temperature with any type of thermometer in the small hold in the white dome lid. If the temperature is below 200°F/100°C, then the cylinder needs to be wrapped with an insulation blanket (left). A simple fabric or fiberglass blanket can be used. The insulation will be very beneficial to the steaming process.

08.06.21

Vertical-Steamer-Instructions